

ZOOMLION

ELECTRIC TELESCOPIC BOOM LIFT

ZT32JE-V

Comply with CE/ANSI/CSA Standard



FEATURES

Standard Features

Horn
Proportional control
All motion alarm
Flashing beacon
Self-closing entry gate
Emergency descent system
Emergency stop button
Auto-leveling system
On-board diagnostic system
Tilt protection system
Oscillating axle
Load sensing system
4.3' Led display
Swing-out engine tray
Swing-out engine tray

Accessories & Options

- ▶ Platform work light
- ▶ Anti-collision device
- ▶ AC power to platform

HIGHLIGHTS

- ▶ Electro-hydraulic system with auto flow controlling , saving energy of 13.8%/9%/10%
- ▶ Safe and reliable lithium battery power system equipped with BMS low-temperature heating and low-temperature charging current control functions improves battery life by 30% and adapts to -20°C cold environment
- ▶ Maintenance-free wheel side AC drive system, the maximum gradeability can reach 45%
- ▶ Fast charging technology adapting to complex charging environment, no fear of wide voltage fluctuations, efficiency increased by 20%
- ▶ Largest electric telescopic boom lift with non-extension axle, work height reaches 34.3m
- ▶ Hexagonal boom design with good stiffness

ACCESS WITH ZOOMLION GREEN

Phone: 0086(731)-88353680 0086(731)-88250971
E-mail: awp@zoomlion.com

Add: 701 Xutong Nan Lu, Xiangjiang New District, Changsha Hunan, China
Web: www.zoomlion-access.com

MAIN SPECS OF ELECTRIC TELESCOPIC BOOM LIFT

ZT32JE-V

Comply with CE/ANSI/CSA Standard

Model	ZT32JE-V	
	Imperial	Imperial
Size		
Work Height	112ft 6in	34.3m
Platform Height	105ft 11in	32.3m
Horizontal Outreach	63ft	19.2m
A - Stowed Length	42ft 4in	12.9m
B - Stowed Width	8ft 2in	2.49m
C - Stowed Height	9ft	2.75m
D - Platform Length	8ft	2.44m
E - Platform Width	3ft	0.91m
F - Wheelbase	9ft 2in	2.80m
Tread	8ft 2in	2.49m
G - Ground Clearance	1ft 4in	0.41m
Performance		
Platform Capacity(Unrestricted/Restricted)	660/1000lb	300/454kg
Drive Speed (Stowed)	3.42mph	5.5km/h
Gradeability	45%(24°)	
Turning Radius (Inside)	10ft 2in	3.11m
Turning Radius (Outside)	20f 3m	6.16m
Turntable Swing	360° continuous	
Platform Rotation	±90°	
Tail Swing	5ft	1.52m
Jib Rotation	135°(-60°~75°)	
Max. Wind Speed	28mph	12.5m/s
Power		
Battery	80V / 460Ah	
Charger	6kW	
Drive Motor	5.2kW	
Lifting Motor	30kW	
Auxiliary Power	2kW	
Hydraulic Tank	33 gal	125L
Tire		
Type	Foam-filled tire Solid tire	
Weight		
Gross	41005lb	18600kg

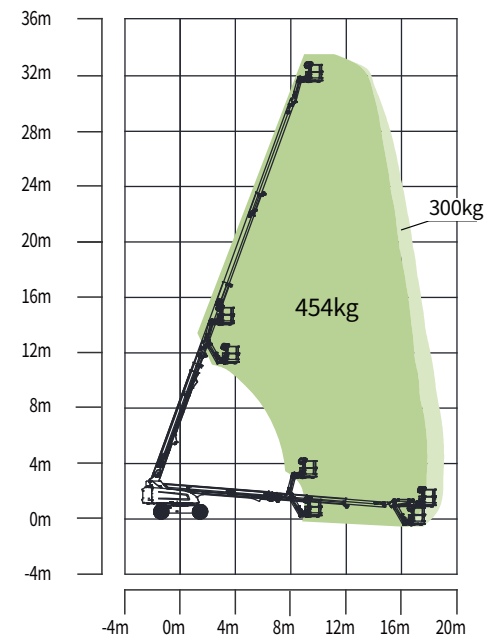
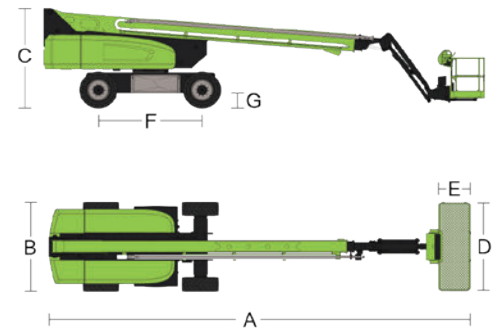

Range of Motion ZT32JE-V